

Operation Manual



BOHP-301

High Performance Oven

Thank you for Choosing Biolab products. Please read the "Operating Instructions" and "Warranty" before operating this unit to assure proper operation.

Index

1. Main Specifications	03
2. The Features of Structure	03
3. Installment Conditions	04
4.Operation Introduction	04
5.The Introduction Of Temperature Controller	05
6.Maintenance	07
7.Failure Process	08
8.Circuit Diagram	09

01 Main Specifications

Model	BOHP-301
Working Room Size	350x350x400 mm (WxDxH)
Temperature Range	+100°C ~ +500°C
Temperature Fluctuation	±0.5°C
Internal Materials	SUS304 stainless steel
External Materials	High quality A3 steel plate
Observation window	✓
Forced Air Circulation	✓
Test shelf	Stainless steel plate x2 pcs
Max Noise	< 65dB
Power supply	240V / 50Hz / 1- phases
Power	3000W

02 The Features of Structure

- External material is used high quality A3 steel plate, the color of surface is sprayed with static technology. So it can avoid rusting and corrosion.
- Internal material is used high quality SUS304 stainless steel, the eight corners were designed to roundness. The surface of working room is smooth, and easy to be cleaned.
- The heat insulating material is superfine glass fiber cotton. This material has perfect insulating effect. So the test result can not be influenced by the environment temperature.
- There is the observation window on the door, users can view the test conditions of specimens conveniently. The material of window is double-layer tempered glass.
- The heat-resistance rubber sealing ring was installed in the edge of observation window, the temperature of working room is more accurate.
- In order to ensure the temperature fluctuation & more stability, the heater was installed in the outside of working room. And users can clean the working room more conveniently.
- The temperature is controlled by micro computer technology. The auto-tuning function is realized by PID controlling. The temperature values are indicated by four digits LED window.

03 Installment Conditions

- When it is moved, users can not push on the window and bump with other hard objects.
- The floor of installation site should be level and stable.
- This oven can not be installed at strong sunshine, high temperature and high humidity environments.
- This oven should be kept away from the electromagnetic interference sources. The ground wire should be connected with ground.
- When users place the specimens into working room, the specimens can not be touched the internal wall of stainless steel.
- Before users connect the power cords with external power source, users should examine that, whether external power source is matching or not. You can know the power standard of this oven by above Main specifications.

04 Operation Introduction

- Placing the specimens:
- Users can open the door and place the suitable specimens into the test shelf, then close the door.
- Start the power of oven:
- Firstly, users can connect the power cords with external power source, click the plug into the socket.
- Secondly, users can start the power switch of panel, then the LED meter start to display the digital data.
- Set the test temperature value and run:
- Users can set the required temperature value on the temperature controller.
- Now the temperature of working room will be reach to the setting value, and the oven is going into running state.
- When the test data is finished, the LED meter will indicate the test is finished.
- Take out the specimens:
- Firstly, Users should close the power switch.
- Secondly, after closed the power switch, users need to wait for about 30 minutes. After the 30 minutes cooling, the temperature of working room is close to environment temperature.

- Now the users can open the door, and take out the specimens.

NOTES:

- When users want to open the door to take out the specimens, users need to know the approximate temperature of working room, avoid scalding.
- Before the oven left factory, its performance is tested strictly. So the users do not need to revise. If the temperature error is high of bad using environment, users can revise it according to the introduction of temperature controller.
- If the users open the door when the test is running, after close the door, the temperature of working room maybe fluctuated, it is normal.
- Users can not put the flammable and volatile specimens into the working room.
- If the oven arises the smell or smoke, the users should shut down the power at once, and then the engineers can check and repair the errors. The users can not do the repairing works during running.

05 The Introduction Of Temperature Controller

Panel:

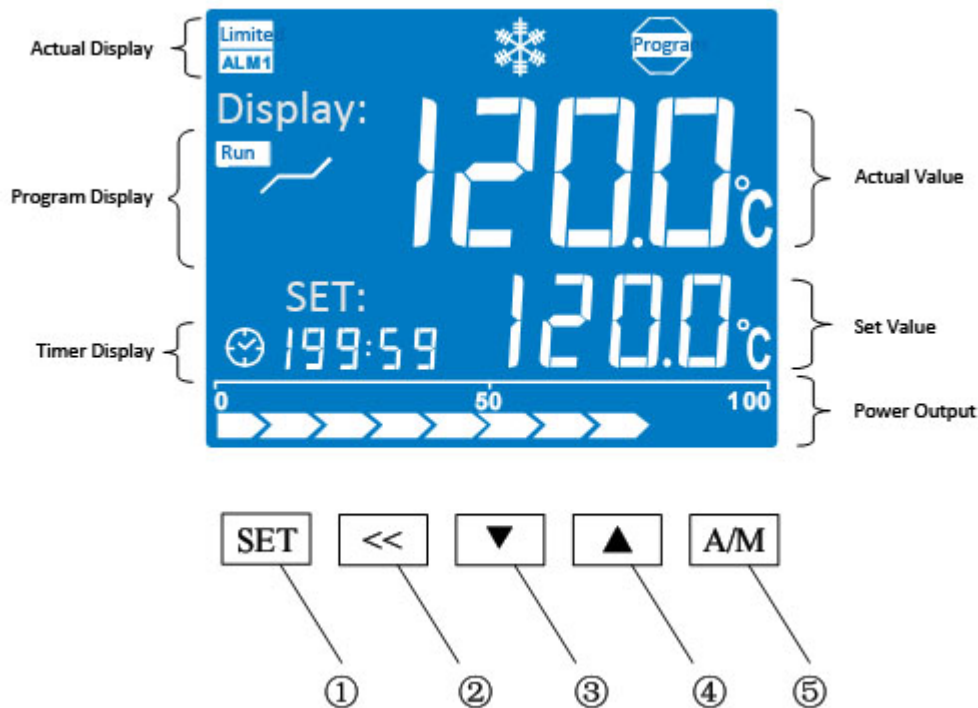

Operation method:

Set the values of temperature and time:

Users can click "SET" button, now users can set the temperature test value. Users can add, reduce and revise the setting data with left, up and down buttons.

After set the temperature test value, users can click "SET" button again, now users can set the test time. It is the same as temperature set, users can add, reduce and revise the setting data with left, up and down buttons.

After set the test time, users can click "SET" button again, now the controller will save and quit the setting interface.

Timing function:

When the test time is set as "0", the controller has no timing function.

When the test time is not set as "0", the controller has the timing function. Now the last decimal point is bright. When the temperature reaches to setting temperature data, the timing function starts to run. Now the last decimal point is flicker.

When the test time is finished, "END" will display at the bottom of controller, the buzzer will be buzzed for 30 seconds. Users can click the "up" button for 4 seconds to eliminate the buzzing sound.

Re-run the previous setting values

If users want to re-run the previous setting values, when the controller displays "END", users can click "down" button for 4 seconds to re-run.

How to re-set the intrinsic parameters?

Users can click "SET" button for 3 seconds, the controller will display the intrinsic parameters interface.

Now the controller displays "LC"(The password prompt), users can change the password to "3" with "left", "up" and "down" buttons. Then click "SET" button again.

After input the password "3", then click "SET" button, users can go into the re-set interface.

Users can re-set the intrinsic parameters according to their requirements.

After re-set, users can click "SET" button for 3 seconds again, then save and leave the re-set interface.

If users stop clicking the buttons longer than 30 seconds, the controller will leave the re-set interface automatically, and the re-set data will be not saved.

Intrinsic parameters functions table

Parameter Indication	Name	Function Introduction	(Range) Original value
Lc-	Password	When "Lc=3", check and re-set values.	0
P--	Proportional Band	Time Proportion Increase "P" value: Increase heating output. Reduce "P" value: Reduce heating output.	(20.0 ~ 80.0) 50.0
AL-	Over-Temperature Deviation Alarm	When "PV \geq SP+AL", buzzer alarm, stop the heat output.	(0.0 ~ 20.0°C) 20.0°C
Pb-	Zero Adjustment	Revise the deviation of temperature sensor. Pb= Actual value – Display value.	(-9.9 ~ 9.9) 0.0
PK-	Full Scale Adjustment	When actual temperature has error deviation, can re-set it. PK=1000x(Actual value – Display value)÷Display value.	(-999 ~ 999) 0.0
rH-	Temperature Test Range	The max test value of temperature.	(0.0 ~ 400.0) 300.0

06 Maintenance

The users need to clean the ovens regularly.

The users can not clean the ovens using acid, alkali or other corrosive solution.

This oven needs to work for more than 2 days in 3 months, ensure the good performance.

If the users do not use this oven for long time, the users should pull up the power cords.

07 Failure Process

Failures (Errors)	Reason	Solution
Power non-load	External power source fault	Change socket
	Bad contact of plug	Check plug
	Fuse is broken	Change fuse
	Switch is close	Open the switch
Non-heating	Lower setting value	Re-set temperature value
	Heater fault	Change heater
	Controller fault	Change controller
	Bad contact of sensor	Check the sensor contact
Temperature deviation is big of actual value and display value.	Sensor fault	Change sensor
	Controller setting values is wrong	Re-set intrinsic parameters
Temperature is out of control	Bad contact of sensor	Check the sensor contact
	Controller fault	Change controller
	SCR fault	Change SCR

08 Circuit Diagram

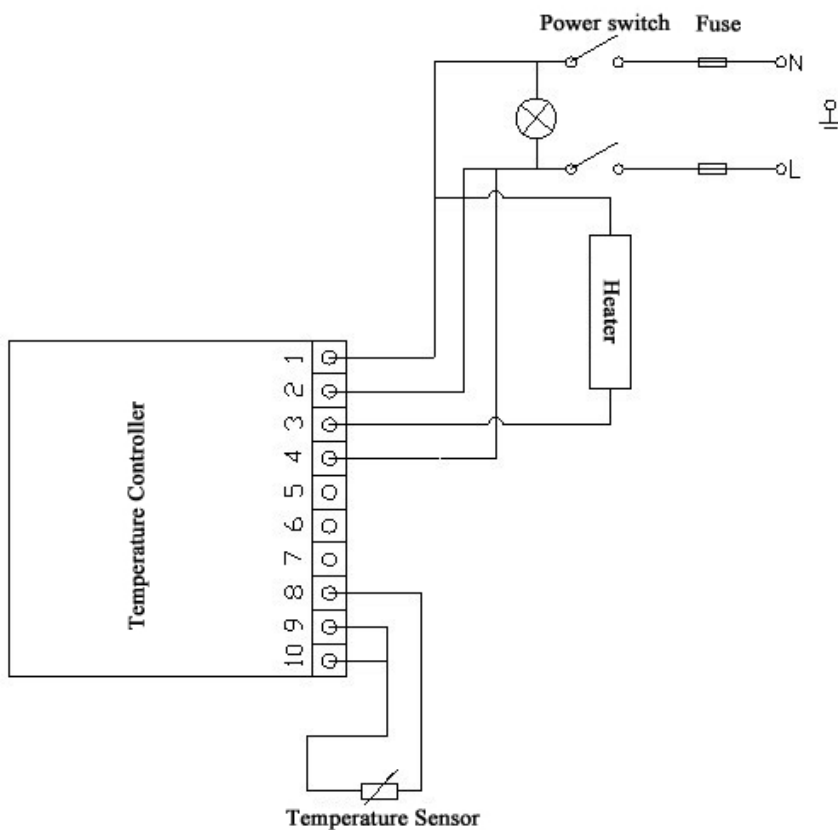

Accessories:

Item	Name	Quantity
1	User manual	1 pc
2	Test shelf	2 pcs
3	Fuse	2 pcs



BIOLAB SCIENTIFIC LTD.

3660 Midland Avenue, Suite 300, Toronto, Ontario M1V 0B8 Canada

Email: contact@biolabscientific.com Tel: +1 707 533 1445

Website: www.biolabscientific.com