

Operation Manual



BOFC-105

Forced Convection Oven

Thank you very much for Choosing Biolab products. Please read the "Operating Instructions" and "Warranty" before operating this unit to assure proper operation.

Index

1. Summary.....	03
2. Structure features.....	03
3. Product structure diagram and parameters.....	04
4. Working conditions.....	05
5. Attentions.....	05
6. Operation instruction.....	06
7. Meter operation instruction.....	07
8. Meter instructions of -230.....	12
9. Fault Treatment.....	15

01 Summary

BOFC New Drying Oven is widely used for drying, baking, melting, sterilizing and curing in labs of industrial enterprises, scientific research institutions, and health and medicine units etc.

02 Structure features

1. High-quality cold rolling steel case with electrostatic spraying surface ensures the aesthetics and longevity of the product.
2. Favin stainless steel working room; foursquare semicircle transition; adjustable shelf, airduct lateral plate and bottom heater covering are knock-down construction, which is convenient for cleaning.
3. PID digital intelligent temperature controller with function of temperature setting, time dual screen displaying, over-temperature alarming and timing.
4. The heater and fan are reasonably constructed by placing them under the working room; circulation fan will be closed when it reaches the target temperature to prevent the powdery sample from blowing away.
5. Independent temperature limiter alarm, which can realize auto-switch with temperature controller; over temperature alarm.
6. Air-tightness adjustable buckle lock door to ensure good sealability.

Optional accessories:

- a. RS485/232 interface, which can be connected with computer by principal computer software to control temperature; convenient to control stopping switch.
- b. Micro type printer, which could continuously print temperature record of the running machine.
- c. Independent power cut alarm system to help the user process sample immediately.
- d. Independent temperature limit alarm system; auto-break-off when over temperature limit.

03 Product structure diagram and parameters

I. Structure diagram

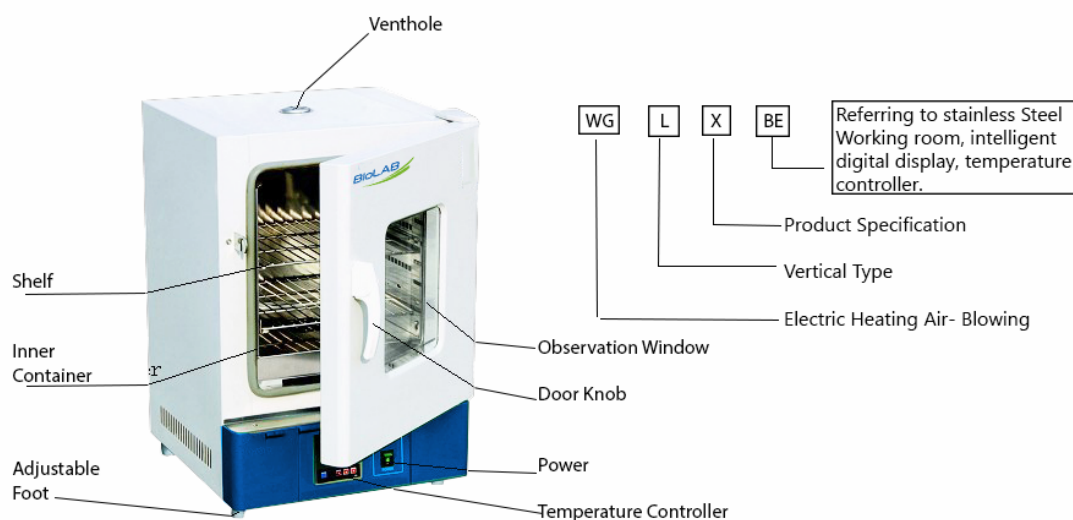

II. Main technical parameters

Model	BOFC-101	BOFC-102	BOFC-103	BOFC-104	BOFC-105
voltage	AC220-240V 50-60Hz				
power(w)	1000W	1400W	1800W	2500W	3200W
Tem. range	RT+10~300°C				
Tem. fluctuation	±1.0°C				
Inner Chamber size W*L*H(mm)	310×310×310	350×350×350	400×360×450	500×450×550	600×500×750
Exterior size W*L*H (mm)	460×510×695	500×550×735	550×550×840	636×680×915	730×670×1220
Shelf load	15/kg				
N.W.(kg)	39	42	47	56	70
Shelf Qty.	2				

III. Temperature profile

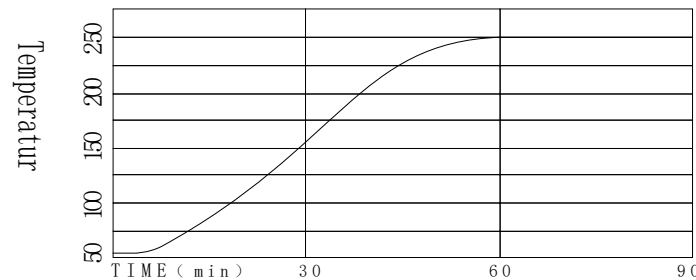

Note: according to the different model type, the time of warming up is different

04 Working conditions

The drying oven work under the following conditions:

1. Temperature ranges between 5~40°C;
2. Relative humidity less than 85% RH;
3. Power: voltage 220-240v, frequency 50-60Hz;
4. No succession and corrosive gas surround the oven.

05 Attentions

1. Install the outer ground protection to ensure safety of machine and experiment; supply power as the machine nameplate required.
2. This equipment is forbid to use in inflammable and explosive, poisonous and strong corrosive experiments.
3. Make sure horizontal installation.
4. Non-professionals are not allowed to disassemble and repair this machine.
5. Pay attention to the setting temperature when dealing with inflammable matters.
6. Make sure dry the resin container, if the temperature is setting too high by accident, the container would be dissolved and then fall on the heater, which will cause fire.
7. Overfilled of sample will lead to overheat of working room under part, which will dissolve the

inflammable material and cause fire.

8. While the machine is working, don't touch the device top, as well as observation window and exhaust port to keep away from high-temperature burns.
9. Read the instruction book before operation.

06 Operation instruction

1. Put the material needs drying into container (advice: size of drying material should not over 2/3 of the shelf); then close the container door and switch power, and next switch on the blower.

2. Heating

Set the temperature as needs (find details in meter instruction), then the temperature starts to rise; when temperature inside working room reaches the set point, the indication light will go out, after constant temperature for 30min, the working room goes into constant temperature state.

Note: don't close blower when the temperature is rising, or else it will accelerate ageing of heater.

3. Working time:

Decide the drying time according to humidity of sample.

Note: for example, if the sample humidity is big, the sample on each layer should not be too thick to ensure intensive drying of sample.

4. After finishing drying, turn off power, and then bring the sample out.
5. Keep the drying oven clean, wipe the container sealing rubber strip by soft cloth and clear the dirt out; avoid cleaning it by chemical solution to prevent chemical reaction damage on sealing rubber strip.
6. If the oven is unused for a long time, daub neutral grease or Vaseline on galvanized parts to prevent corrosion; cover the oven with plastic dust cap, and store it in the dry room to keep the electric device against wet.

07 Meter operation instruction

i. Panel Instructions

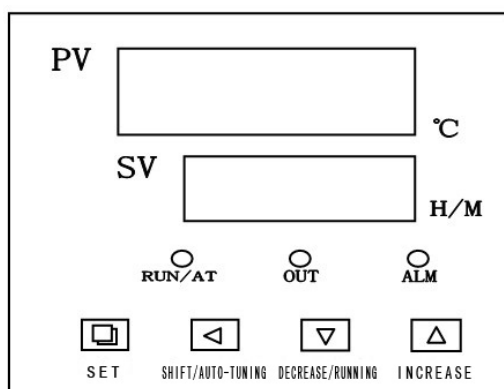

ii. Indicator definition

1. "RUN/AT" indicator: This indicator is bright when the controller is running, when the runtime is over, this indicator is not bright. When the controller enters the auto-tuning of PID, this indicator is flashing.
2. "OUT" indicator: If the heater output turns on, this indicator is bright, else this indicator is not bright.
3. "ALM" indicator: When the over-temperature alarm occurs, this indicator is bright.

iii. Operation and using

1. When the controller is switched on, display windows show "In index (P, C, K, S)" and the value of temperature range for 3 seconds, then it starts running.

2. Temperature and time settings:

Press the "Set" button, the controller runs into the temperature setting state. Re-press the "Set" button, the controller runs into the time setting state. In setting state, you can use the "◀", "▼" and "▲" buttons to get the required settings. Press the "set" button again, it returns from the setting state and the settings are saved automatically.

If the time is set as "0", the controller will run continuously, the display window of "SV" will display the set point temperature.

If the time set value is not equal "0", timers start time when the measuring temperature reaches the set point temperature, the display window of "SV" will display the runtime.

If En = 0, when the runtime is over, the "sV" window will display "End", the buzzer will sound for 30s, off all outputs;

If En = 1, when the runtime is over, the "sV" window don't show "End", the buzzer sounds for 30 seconds, temperature Continue to constant temperature; After the end of operation, long press" shift / run" button for 3 seconds can restart the timer operation.

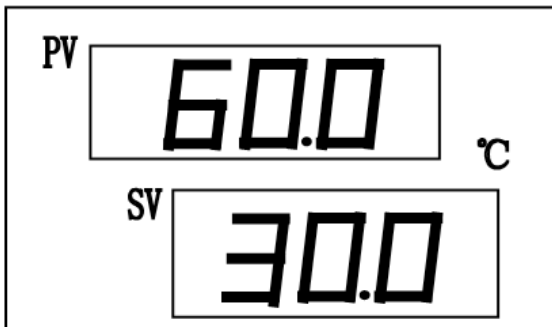

(1)The normal display

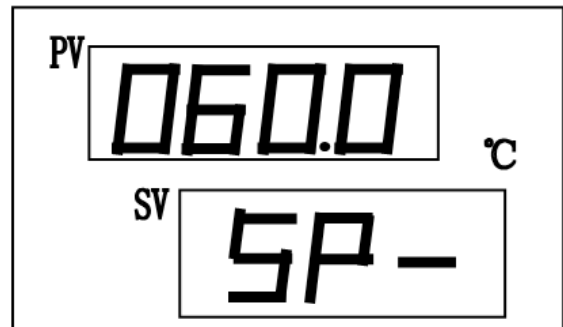

(2) the temperature setting state

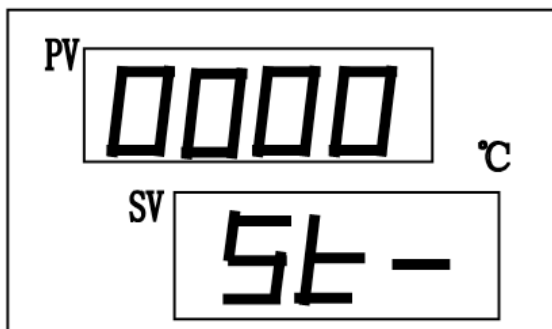

(3)the time setting state

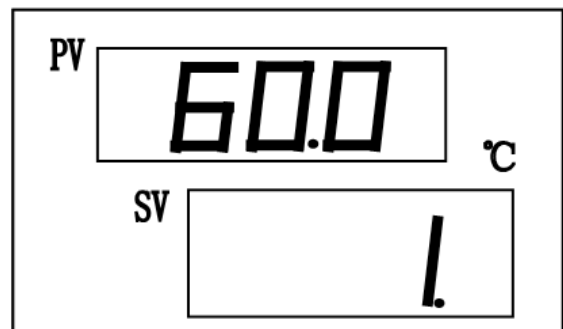

(4)Timing display

3. When temperature alarm, the buzzer will sound, "ALM" lights. If a change in temperature setting and over-temperature alarm, "ALM" lights up, but no songs buzzer.

4. When the buzzer sounds, it can be muted by pressing any button.

5. "◀" button: In the setting state, it can shift the set value by pressing the button.

6. "▼" button: In the setting state, it can reduce the set value by pressing the button. If press and hold the button, the set value will reduce continuously.

7. "▲" button: In the setting status, it can increase the set value by pressing the button. If press and hold the button, the set value will increase continuously.

8. In setting state, the controller will return to run status if without any key press in one minute.

9. If the display window shows "----", it indicates the fault of temperature.

iv. AT function

When the temperature control effect is not ideal for system tuning. Self tuning process temperature can have bigger overshoot, the users in a system setting before please consider this factor.

In not running state, the controller will enter the auto-tuning of PID by pressing the "◀" button for 6s, "RUN/AT" indicator flashes, it will be not bright when the auto-tuning of PID is completed. In the state, compressor into normally open mode, when the auto-tuning of PID after the end of a group of PID parameter, parameter automatic save and return to the normal mode of operation. When running the auto-tuning of PID, it can be stopped by pressing the "◀" button for 6s again.

In the auto-tuning of PID state, if temperature alarm, no songs buzzer and "ALM" don't light ,but heating alarm relay automatic disconnect. And "set" keys to effective. In the system self tuning process regardless of whether there is a constant temperature time setting, controller display window lower always display the temperature setting value.

v. Internal parameters settings

Press the "Set" button for 3 seconds, controller will display the password prompt "Lc". Adjust the password to the required value, then press the "Set" button again, it will run into the internal parameter setting state. if press the "Set" button for another 3 seconds, it will return to the running state.

Parameter list-1:

Parameter indicator	Name	Instruction of the Parameter's function	(Setting range) factory set value
Lc-	Password	when Lc=3 ,then we can see and modify parameters	0
AL-	Alarming setting	When temperature is beyond "SP+AL", the Alarm indicator turns on. The buzzer sounds and the heater output turns off.	(0~100°C) 15
T-	Control cycle	The heat control cycle of temperature	(1~60S) Note 1
P1-	Proportional band 1	Adjustment of proportional parameter.	(1.0~rH) 30
I1-	Integration time 1	Adjustment of integration parameter.	(1~1000S) 400
d1-	Differential time 1	Adjustment of differential parameter.	(0~1000S) 200
P2-	Proportional band 2	Adjustment of proportional parameter.	(1.0~rH) 25
I2-	Integration time 2	Adjustment of integration parameter.	(1~1000S) 150
d2-	Differential time 2	Adjustment of differential parameter.	(0~1000S) 150
dc-	Turnover Temperature	It selects the different PID according to the set value of temperature	(0~range)80°C
Pb-	Zero point adjust	When the zero error comparatively larger, to update this value should be needed. Pb=measure value –actual value	(-50~50°C) 0
PK-	Full point adjust	When the full point error also comparatively larger, to update this value should be needed. PK= 1000×(measure value –actual value)/ actual value.	(-999~999) 0

Et-	Timing function	When ET = 0, no timing function; 1 electric start timing, 2 to the value set start timing.	(0~2) Note 2
------------	-----------------	--------------------------------------------------------------------------------------------	--------------

Note 1 If the selection of relay output, heating control cycle should be selected in 20 seconds, the other models for 5 seconds.

Note 2 If FCD-300X series, a timing function for 2, other models for 0.

Parameter list-2:

Parameter indicator	Name	Instruction of the Parameter's function	(Setting range) factory set value
Lc-	Password	when Lc=9, then we can see and modify parameters	0
Co-	Turn off the heat output deviation	When "PV ≥ SP + Co", Turn off the heating output	(0.0~50.0°C) 5.0
Hn-	Constant temperature time mode	0: minutes time; 1: hours time	(0~1) 0
En-	End of operation temperature	En = 0 end of run off output; En = 1 end run to constant temperature;	(0~1) 0
Lt1-	Maximum power output 1	The heating output maximum power percentage;	(0~100) 70
Lt2-	Maximum power output 2	The heating output maximum power percentage;	(0~100) 100
rH-	Range of temp setting	The value of temperature setting.	Note 3

Note 3: FCD-30XX: 0~400.0°C(300°C); FCD-31xx: 0~100.0°C(100°C);

FCD-3Kxx: 0~1200(1200°C); FCD-3Sxx: 0~1600°C; (1500°C)

Parameter list-3:

Parameter indicator	Name	Instruction of the Parameter's function	(Setting range) factory set value
Lc-	Password	when Lc=23,then we can see and modify parameters	0
bd	Internal Parameters	Customers should according to the Initial value	(0~1)0
ad	Address	Communication address	(0~32)1
p-t	Print interval	When p-t=0,no print	(0-9999s)0s

English name and parameter indicating the symbol table

Parameters indicating	SP	St	Lc	AL	T	P	I	d
English Name	SP	St	Lc	AL	T	P	I	d
Parameters indicating	Pb	Pk	Co	Hn	oP	rH		
English Name	Pb	Pk	Co	Hn	oP	rH		

vi. Wiring

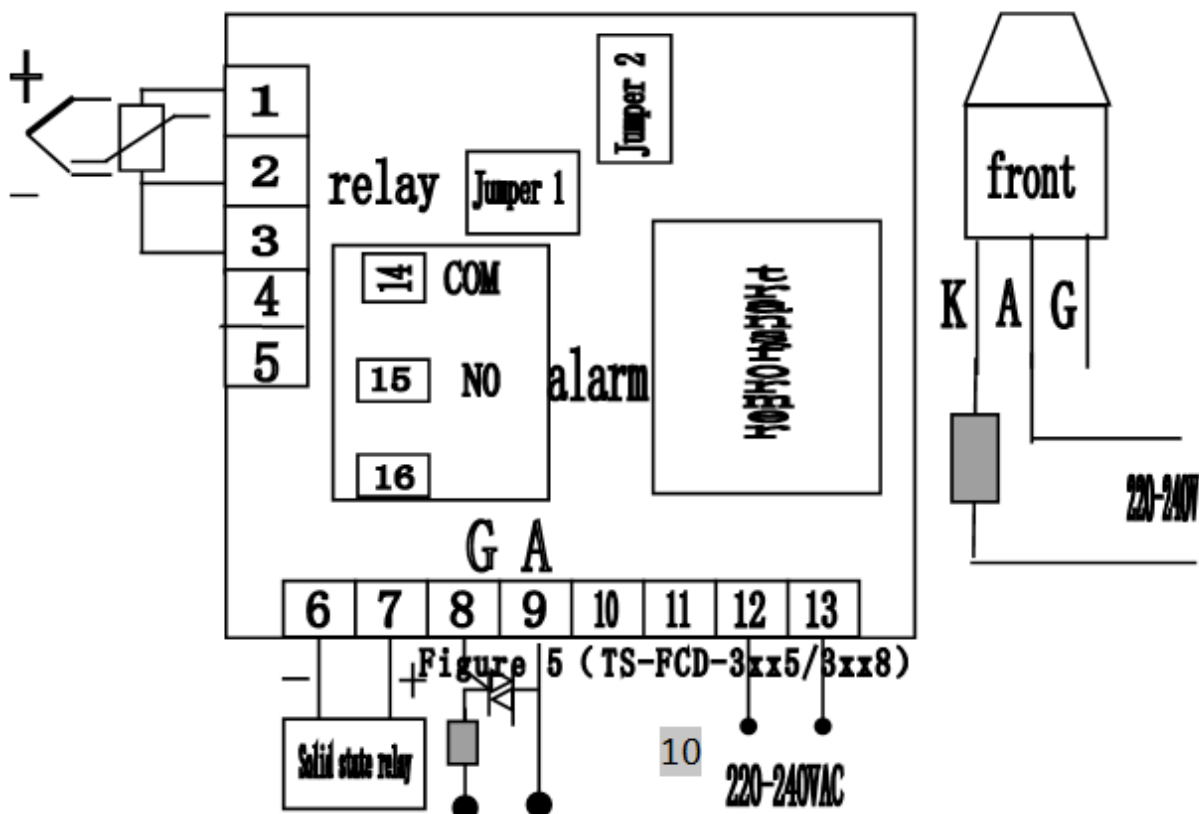

08 Meter Instructions of -230

a. Brief introduction

1: Shape size: 170mm*60mm;

2: Range of temperature: 1) FCH-20xx:0~400.0°C; 2) FCD-31xx: 0~100.0°C;

Range of time: 0~9999 Minute(Hour);

3) Temperature display value of basic error: < 0.5%;

4) Working environment:

Main board Power:220-240V AC;

Environmental temperature: 0~50°C;

Relative Humidity: <85%RH;

b. Panel Instructions

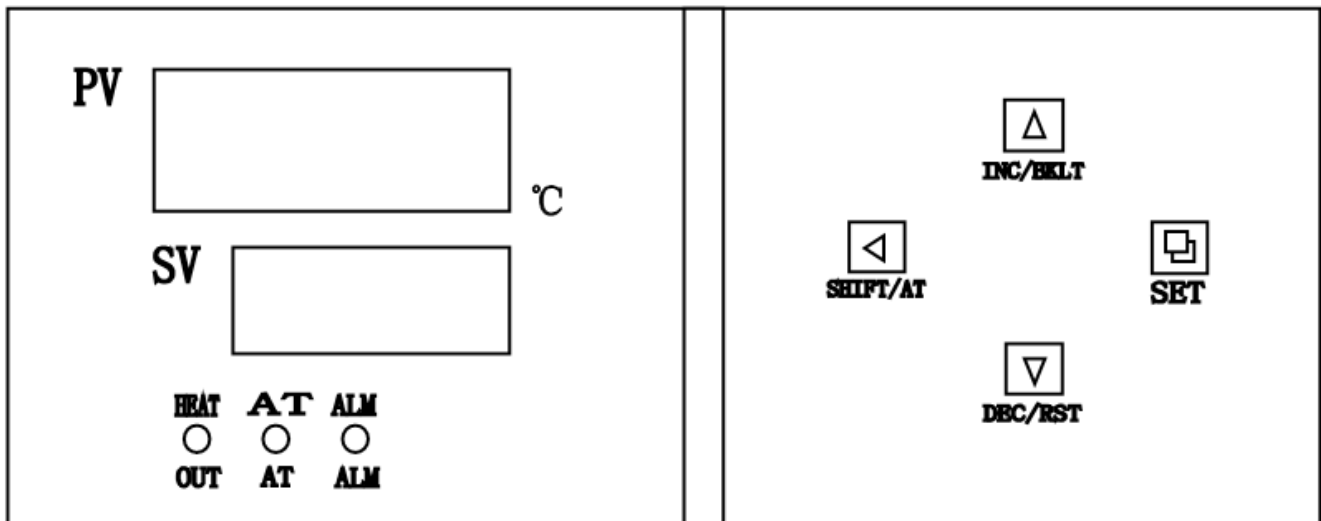

c. Indicator definition

1) "OUT" indicator: If the heater output turns on, this indicator is bright, else this indicator is not bright.

2) "AT" "When the controller enters the auto-tuning of PID, this indicator is flashing.

3) "ALM" indicator: When the over-temperature alarm occurs, this indicator is bright.

d. Operation and using

1) Temperature and time settings:

Press the "Set" button, the controller runs into the temperature setting state. Re-press the "Set" button, the controller runs into the time setting state. In setting state, you can use the "◀", "▼" and "▲" buttons to get the required settings. Press the "set" button again, it returns from the setting state and the settings are saved automatically.

If the time is set as "0", the controller will run continuously, the display window of "SV" will display the set point temperature. If the time set value is not equal "0", timers start time when the measuring temperature reaches the set point temperature, the display window of "SV" will display the runtime.

2) When temperature alarm, the buzzer will sound, "ALM" lights. If a change in temperature setting and over-temperature alarm, "ALM" lights up, but no songs buzzer.

3) When the buzzer sounds, it can be muted by pressing any button.

- 4) "◀" button: In the setting state, it can shift the set value by pressing the button.
- 5) "▼" button: In the setting state, it can reduce the set value by pressing the button. If press and hold the button, the set value will reduce continuously.
- 6) "▲" button: In the setting status, it can increase the set value by pressing the button. If press and hold the button, the set value will increase continuously.
- 7) In setting state, the controller will return to run status if without any key press in one minute.
- 8) If the display window shows "----", it indicates the fault of temperature.

e.AT function

When the temperature control effect is not ideal for system tuning. Self tuning process temperature can have bigger overshoot, the users in a system setting before please consider this factor.

In not running state, the controller will enter the auto-tuning of PID by pressing the "◀" button for 6s, "RUN/AT" indicator flashes, it will be not bright when the auto-tuning of PID is completed. In the state, compressor into normally open mode, when the auto-tuning of PID after the end of a group of PID parameter, parameter automatic save and return to the normal mode of operation. When running the auto-tuning of PID, it can be stopped by pressing the "◀" button for 6s again.

In the auto-tuning of PID state, if temperature alarm, no buzzer and "ALM" don't light, but heating alarm relay automatic disconnect. And "set" keys to effective. In the system self tuning process regardless of whether there is a constant temperature time setting, controller display window lower always display the temperature setting value.

f.Internal parameters settings

Press the "Set" button for 3 seconds, controller will display the password prompt "Lc". Adjust the password to the required value, then press the "Set" button again, it will run into the internal parameter setting state. if press the "Set" button for another 3 seconds, it will return to the running state.

Parameter list-1:

Parameter indicator	Name	Instruction of the Parameter's function	(Setting range) factory set value
Lc-	Password	when Lc=3, then we can see and modify parameters	0
AL-	Alarming setting	When temperature is beyond "SP+AL", the Alarm indicator turns on. The buzzer sounds and the heater output turn off.	(0~100°C) 5
T-	Control cycle	The heat control cycle of temperature	(1~60S) Note 1
P-	Proportional band	Adjustment of proportional parameter.	(1.0~rH) 30
I-	Integration time	Adjustment of integration parameter.	(1~1000S) 400
d-	Differential time	Adjustment of differential parameter.	(0~1000S) 200
Pb-	Zero point adjust	When the zero error comparatively larger, to update this value should be needed. Pb=measure value –actual value	(-50~50°C) 0

PK-	Full point adjust	When the full point error also comparatively larger, to update this value should be needed. PK= 1000×(measure value –actual value) / actual value.	(-999~999) 0
-----	-------------------	-----------------------------------------------------------------------------------------------------------------------------------------------------------	--------------

Note 1: If the selection of relay output, heating control cycle should be selected in 20 seconds, the other models for 5 seconds.

Parameter list-2:

Parameter indicator	Name	Instruction of the Parameter's function	(Setting range) factory set value
Lc-	Password	when Lc=9, then we can see and modify parameters	0
Co-	Turn off the heat output deviation	When "PV≥SP+Co", Turn off the heating output.	(0.0~50.0°C) 5.0
En-	End of operation temperature	En = 0 end of run off output; En = 1 end run to constant temperature;	(0~1) 0
oP-	Door control	0: Disable the function of door control; 1: Enable the function of door control.	(0~1) 1
rH-	Range of temp setting	The value of temperature setting.	(0~400.0°C) 300.0

English name and parameter indicating the symbol table

Parameters indicating	SP	St	Lc	AL	T	P	I	d
English Name	SP	St	Lc	AL	T	P	I	d
Parameters indicating	Pb	Pk	Co	Hn	oP	rH		
English Name	Pb	Pk	Co	Hn	oP	rH		

g.Wiring

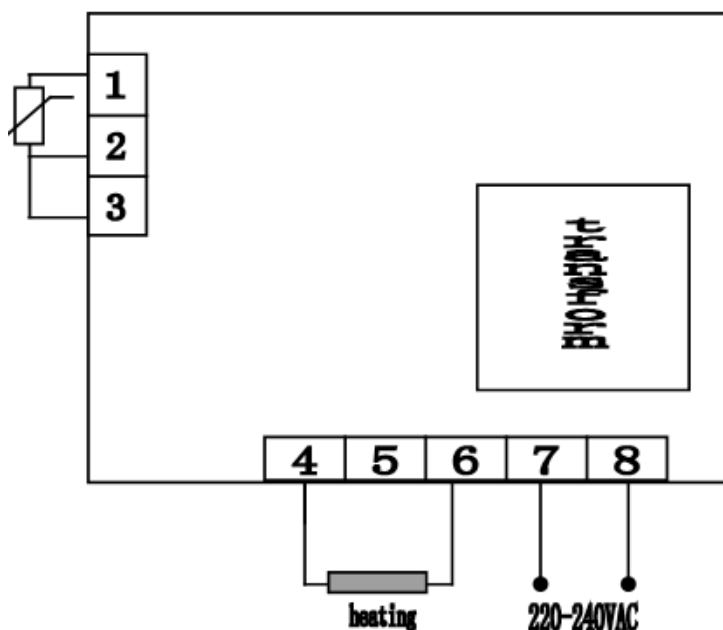

09 Fault treatment

Phenomena	Causation	Treatment Method
1.No power supply	1.Plug is poor contact or line broke	1. Connect the plug and line.
	2. Fuse protector is broke.	2. Change the fuse protector.
2. No temperature rising inside container	1. Low setting temperature	1. Readjust and set temperature
	2. Heater is broke.	2. Change the heater
	3.Temperature controller is broke	3. Change the temperature controller
	4. Temperature sensor is loose.	4. Screw up the sensor nut.
	5. Temperature sensor is broke	5. Change the temperature sensor.
3. No temperature rising alarm	1. Setting temperature of Detached temp. limiter is low	1. Readjust the temperature 30°C above setting temperature.
	2. Detached temperature limiter sensor is broke.	2. Change the detached temperature limiter sensor

4. Temperature cannot reach the setting point.	1. Exhaust port is fully opened	1. Shut off the exhaust port.
	2. The container is overfilled, hot air cannot convert.	2. Decrease amount of sample to improve convection condition.
5. The fan does not work.	The fan motor is broke	Stop work and check electric capacity and motor
6.Displaying-----	The sensor is broke	Change the sensor
7.Display STOP	Time-up	Press the program key for 3s to start

Notes



BIOLAB SCIENTIFIC LIMITED
91 Trafford Crescent, Markham, Ontario,
L3R 7J3, Canada

 +1 707 533 1445

|  info@biolabscientific.com

|  www.biolabscientific.com